

# MASTEA

by Matteo Zorzenoni

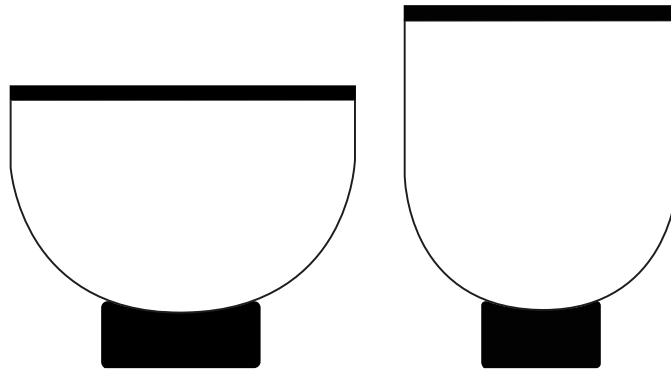

Erano gli anni '70 quando abbiamo cominciato a sperimentare con il vetro di Murano e, anche se le generazioni sono cambiate, il vetro si soffia come una volta: ci vogliono un maestro vetraio e due polmoni forti. Lavorare al giorno d'oggi con questo materiale è come rivisitare un piatto della tradizione. Gli ingredienti rimangono gli stessi, ma nel sapore trovi qualcosa di nuovo.

We started to experiment with Murano glass in the 1970s and, even if the generations have changed, the glass is blown as it once was: it needs a master glassblower and two strong lungs. Working with this material every day is like revisiting a traditional dish. The ingredients are the same but there is something new in the taste.

## DIMENSIONI | DIMENSIONS



lunghezza | width: 49,5 cm  
larghezza | depth: 49,5 cm  
altezza | height: 42 cm

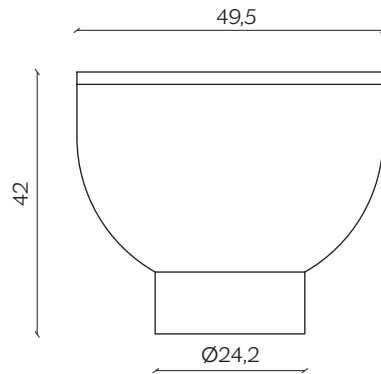

lunghezza | width: 35 cm  
larghezza | depth: 35 cm  
altezza | height: 52 cm

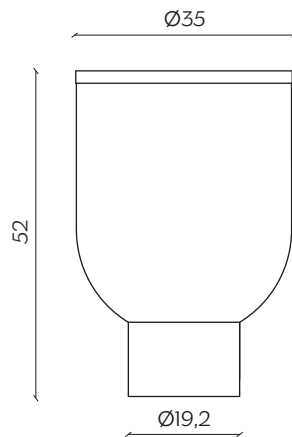

## AMBIENTE | ENVIRONMENT

interno | indoor

## DOWNLOAD | DOWNLOADS

la guida Cura e Manutenzione è disponibile su [miniforms.com](https://miniforms.com)  
Care and Maintenance guide is available at [miniforms.com](https://miniforms.com)

file 2D, 3D e fotografie sono disponibili su [miniforms.com](https://miniforms.com)  
2D, 3D files and hi-res images are available at [miniforms.com](https://miniforms.com)

## FINITURE | FINISHES

### VETRO | GLASS

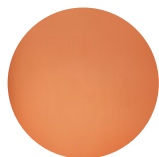

Vetro Soffiato  
Ambra  
Amber Blown  
Glass

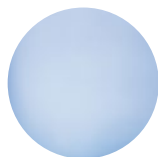

Vetro Soffiato  
Blu  
Blue Gray Blown  
Glass

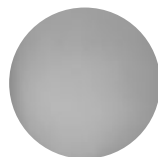

Vetro Soffiato  
Grigio  
Smoked Gray  
Blown Glass

### LEGNO | WOOD



Frassino  
Ash



Frassino Tinto Noce  
Ash Stained Walnut

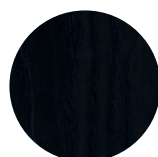

Frassino Nero  
Black Ash